

Consumer eSIM: Opening up new opportunities for mobile operators

Gary Waite

16 December 2021

Gary Waite



With over 30 years' experience across the telecommunications and mobile sector, Gary has been key to the success of SIM technology ever since its inception. He helped author the original ETSI SIM technical specifications, then via a start-up, he designed and sold what became the de facto standard SIM & Mobile test tool for the entire mobile industry.

He has worked in industry for companies both large and small including Telefonica group, and is considered an expert on eSIM, NFC, Mobile Wallet and M2M/IoT. More recently, Gary was in charge of the GSMA's Consumer eSIM technical specification development and has been key to the global market adoption of both the GSMA IoT and Consumer eSIM standards.

Consumer eSIM

eSIM

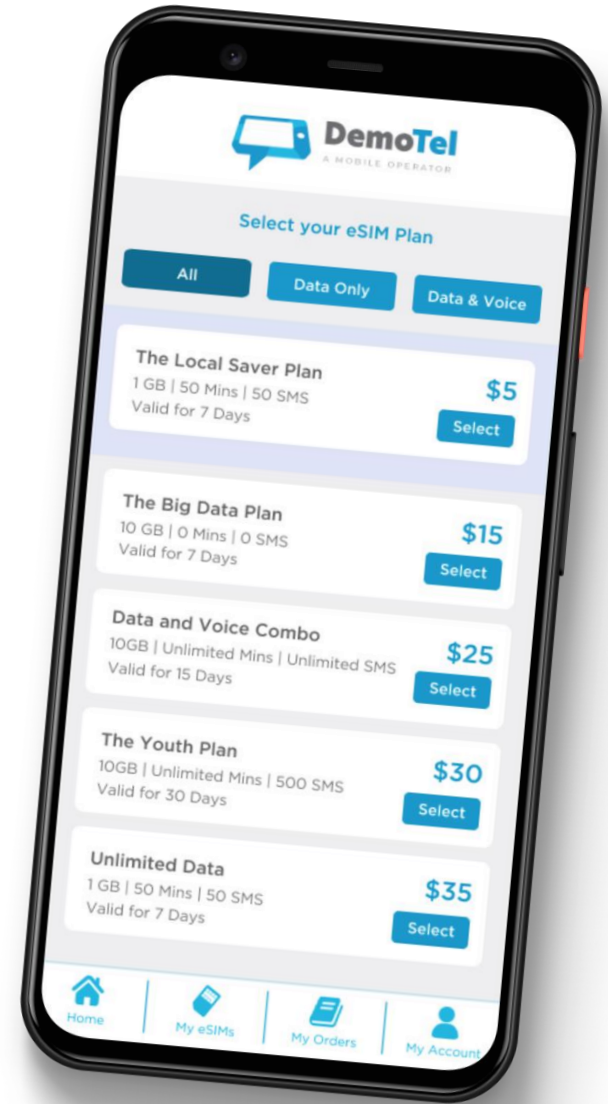



Efficient new sales

Faster & lower cost customer acquisition



Physical distribution of SIM cards

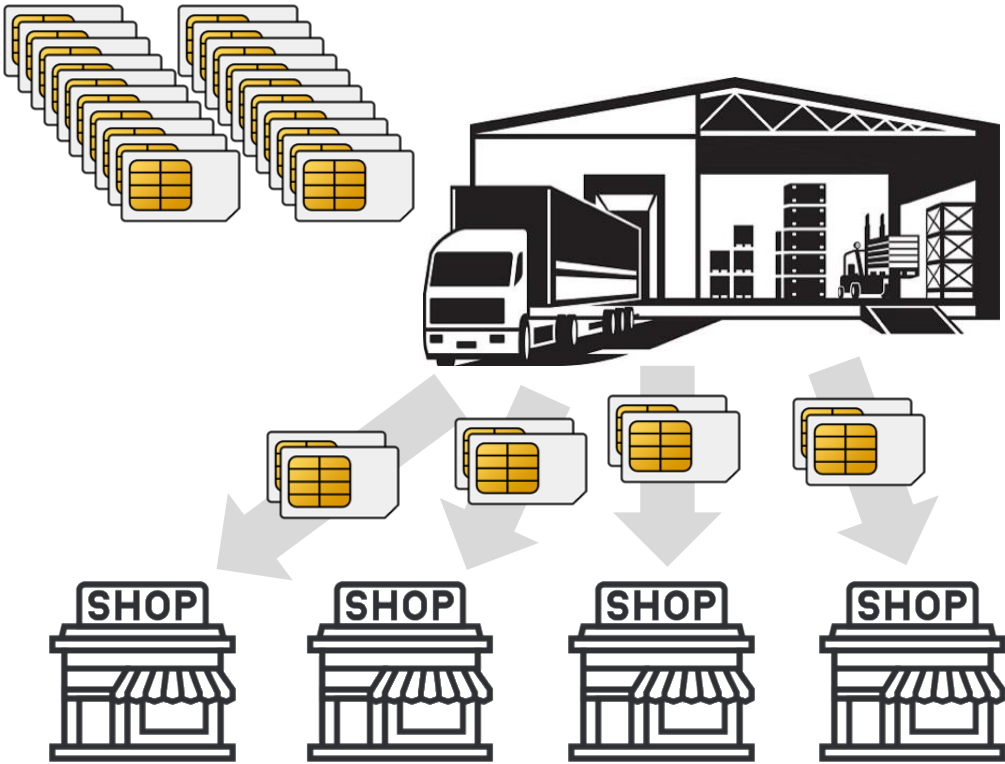

Digital download of eSIM plans



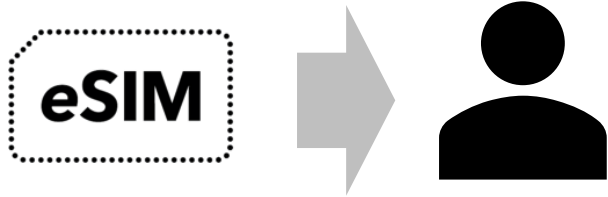

Faster connection of new customers

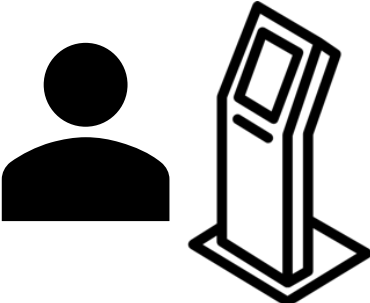

Lower cost retail outlets



New online sales experience

An example online experience with eSIM

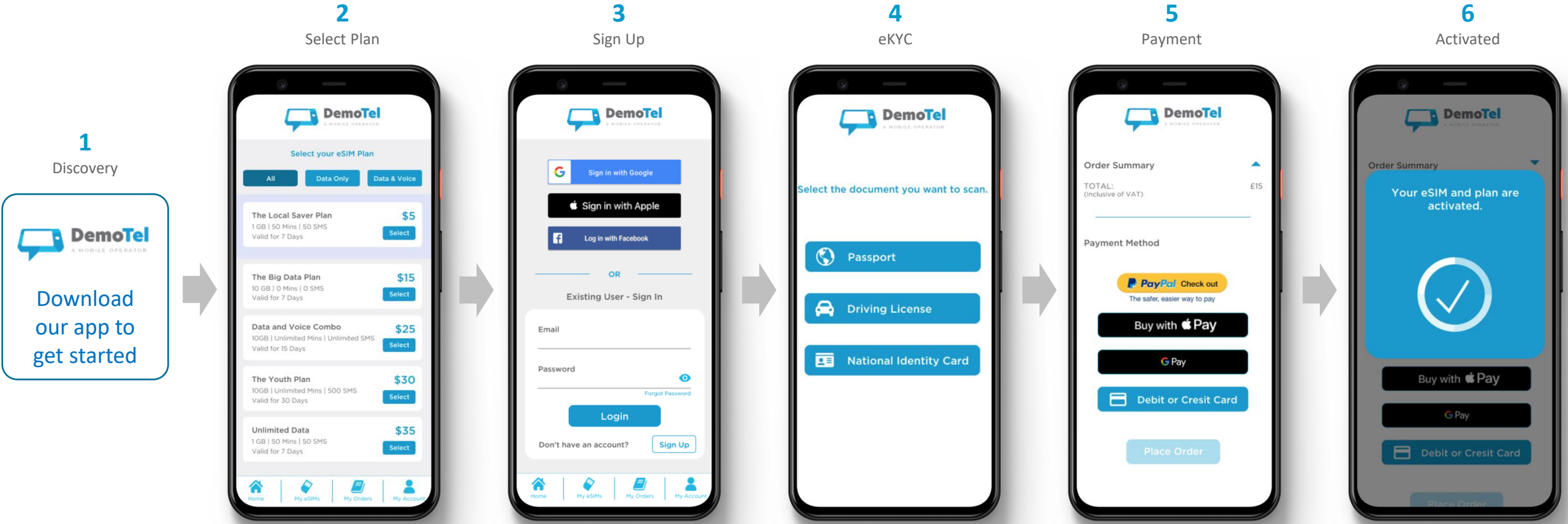



Multi-product packages

Greater customer retention



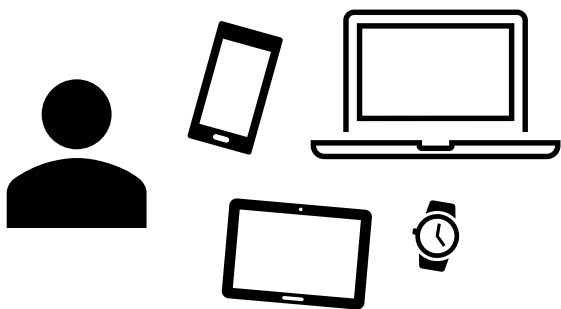

Easy addition of more devices to the customer's account

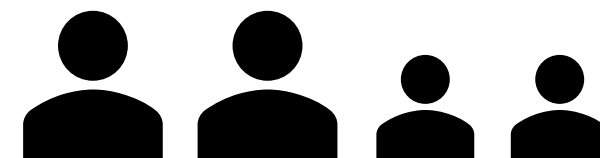

Easy addition of more devices for the family (one bill)

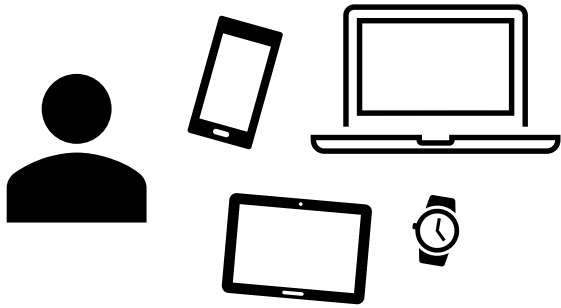

Easy addition of more devices to the customer's account

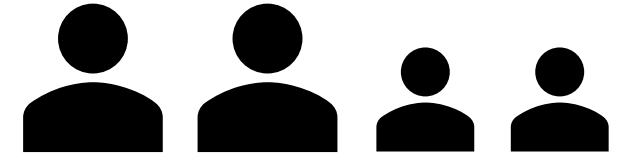

Easy addition of more devices for the family (one bill)

Connection of all manner of home appliances and devices

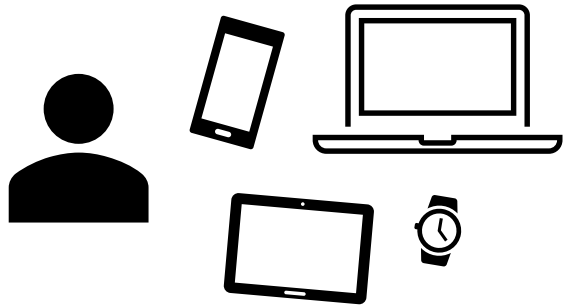

Easy addition of more devices to the customer's account

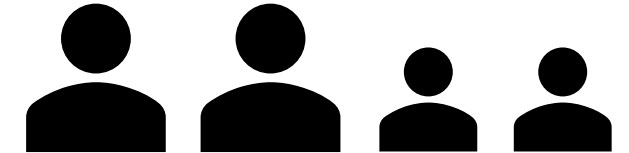

Easy addition of more devices for the family (one bill)

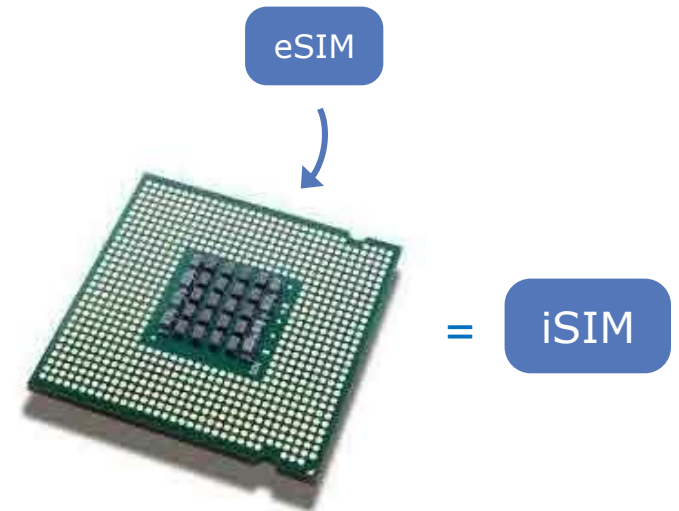
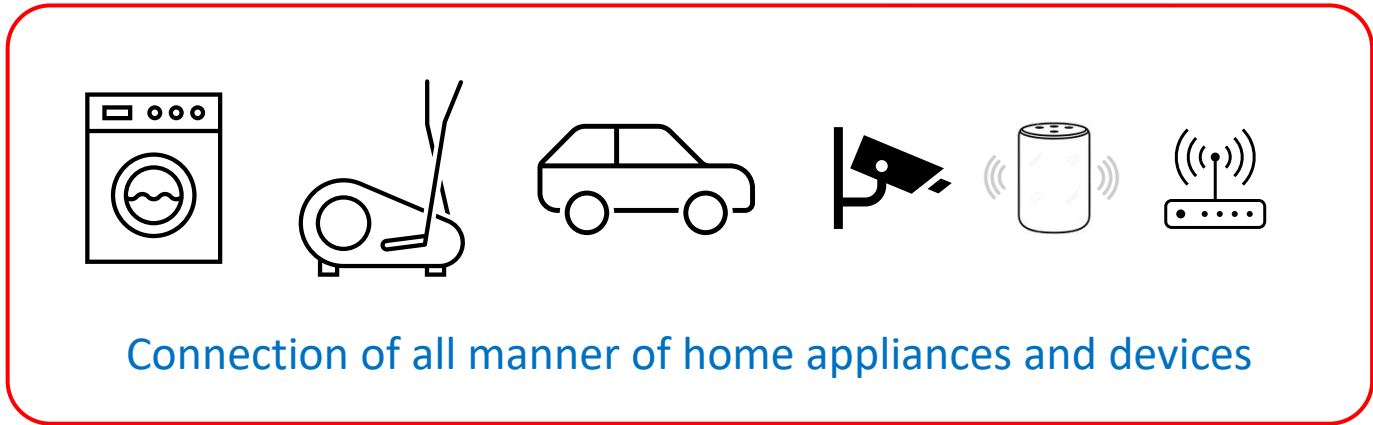

Travel



Operator

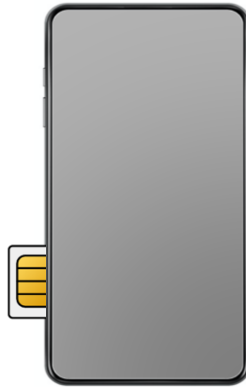

SIM only

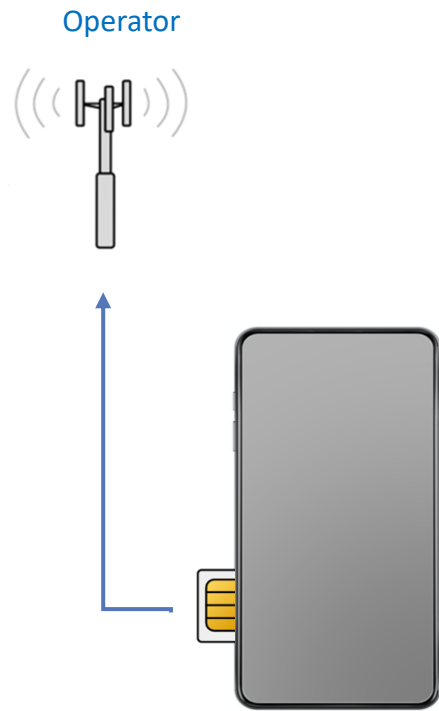

SIM only

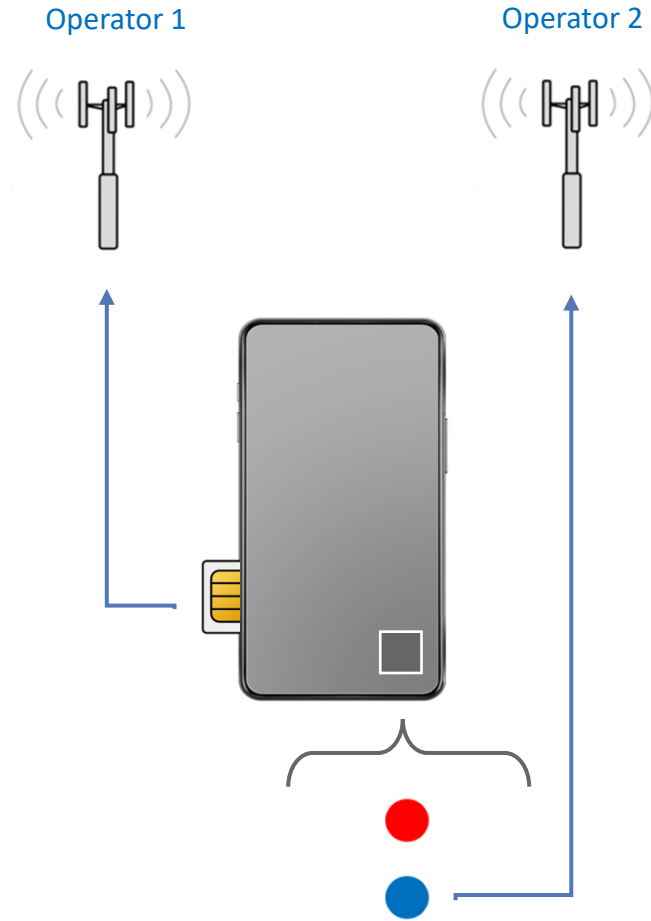

SIM + eSIM

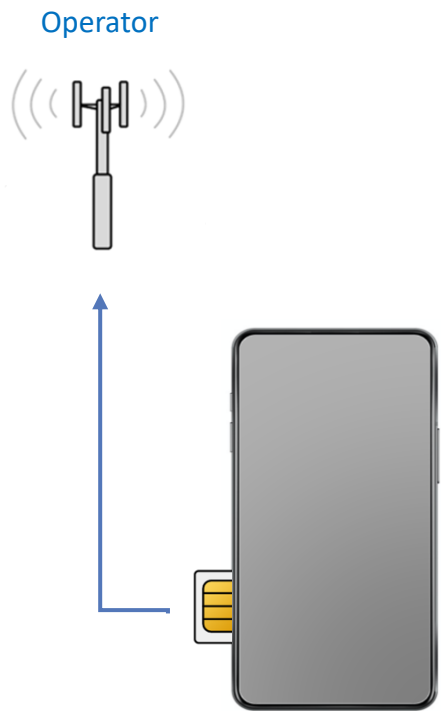

SIM only

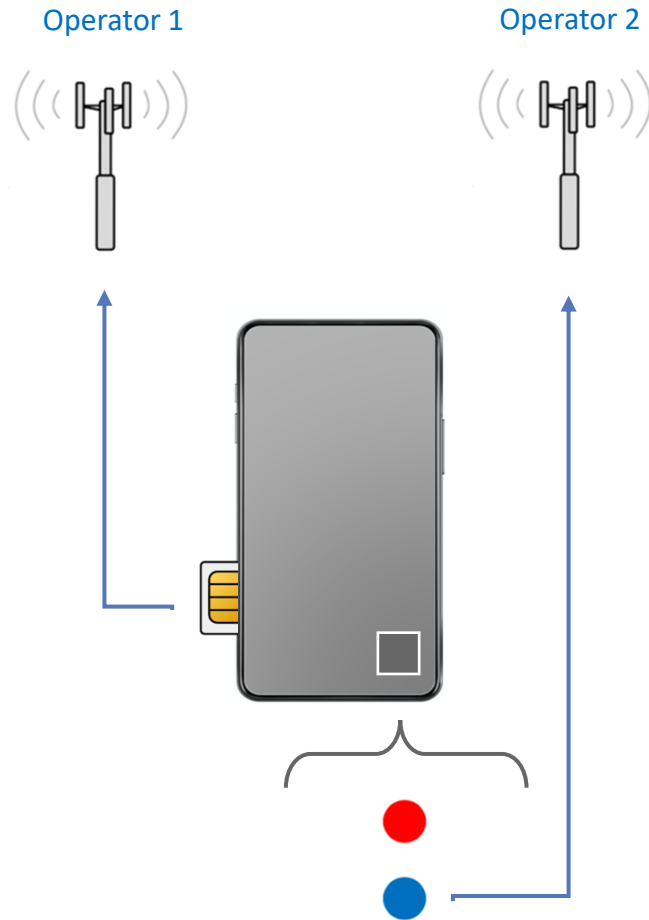

SIM + eSIM

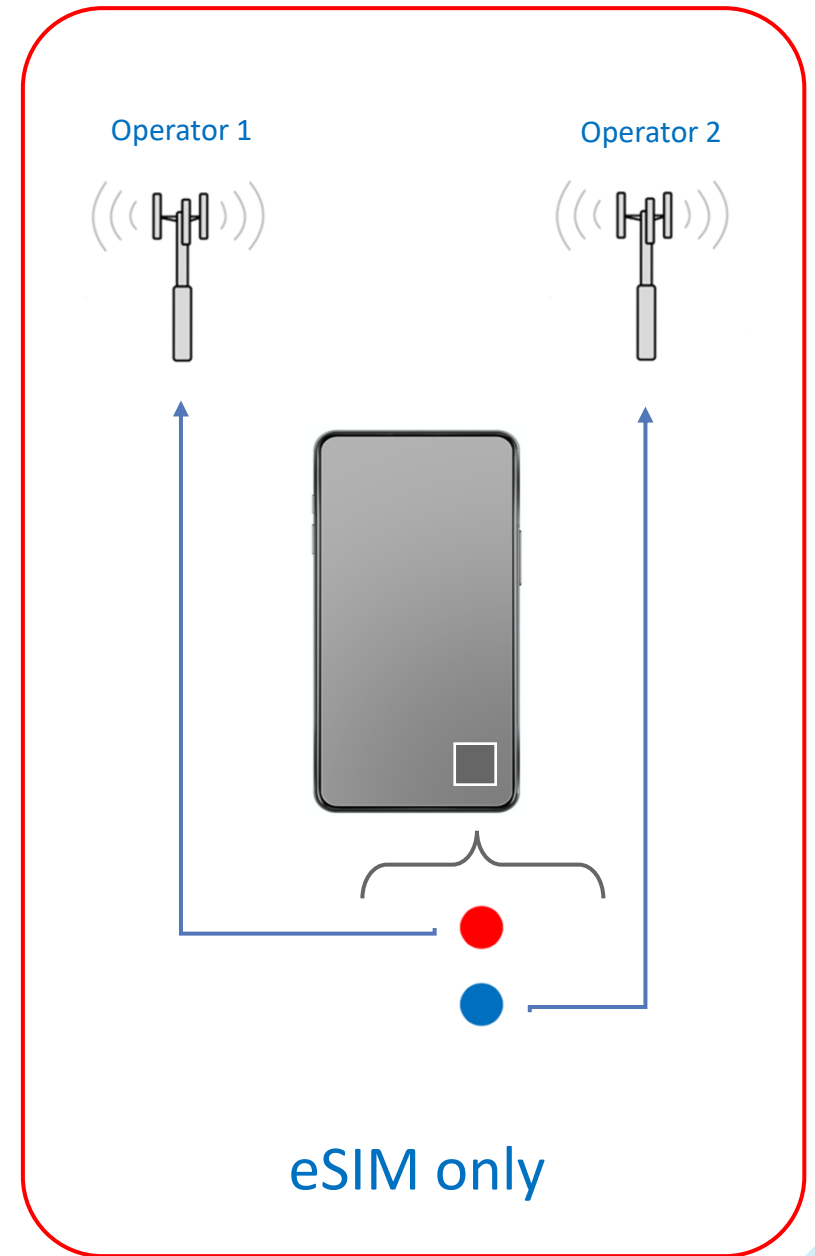

eSIM only

Inbound Travellers



Outbound (Prepaid) Travellers

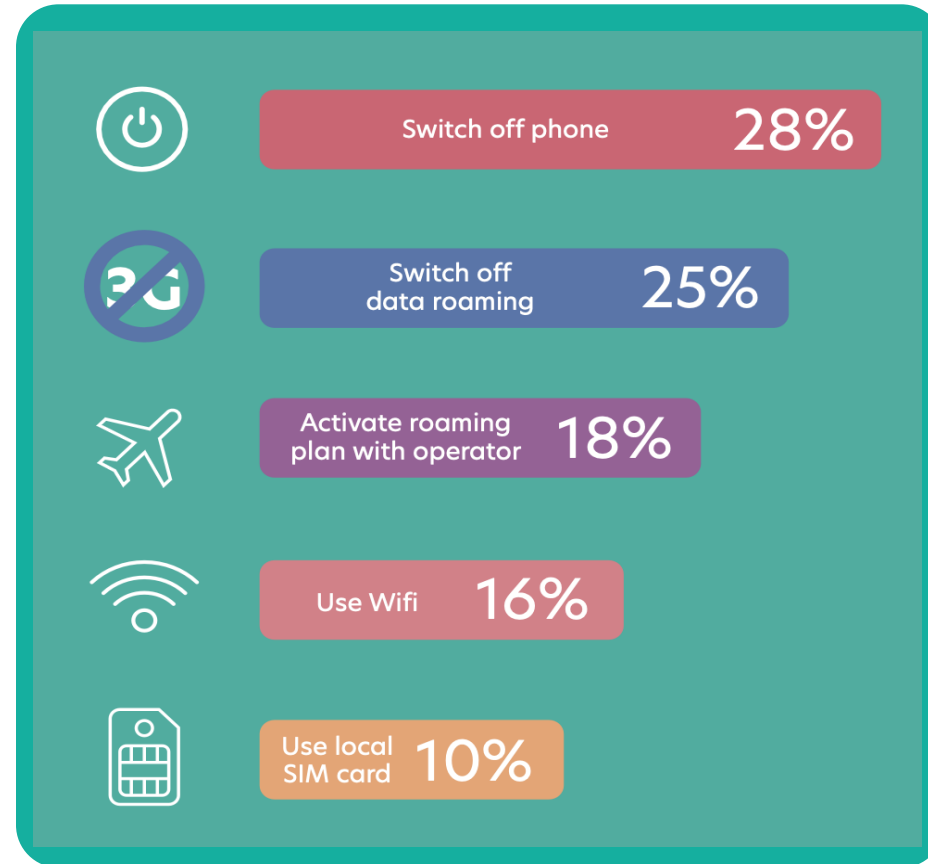

Outbound (Prepaid) Travellers





Try Before You Buy



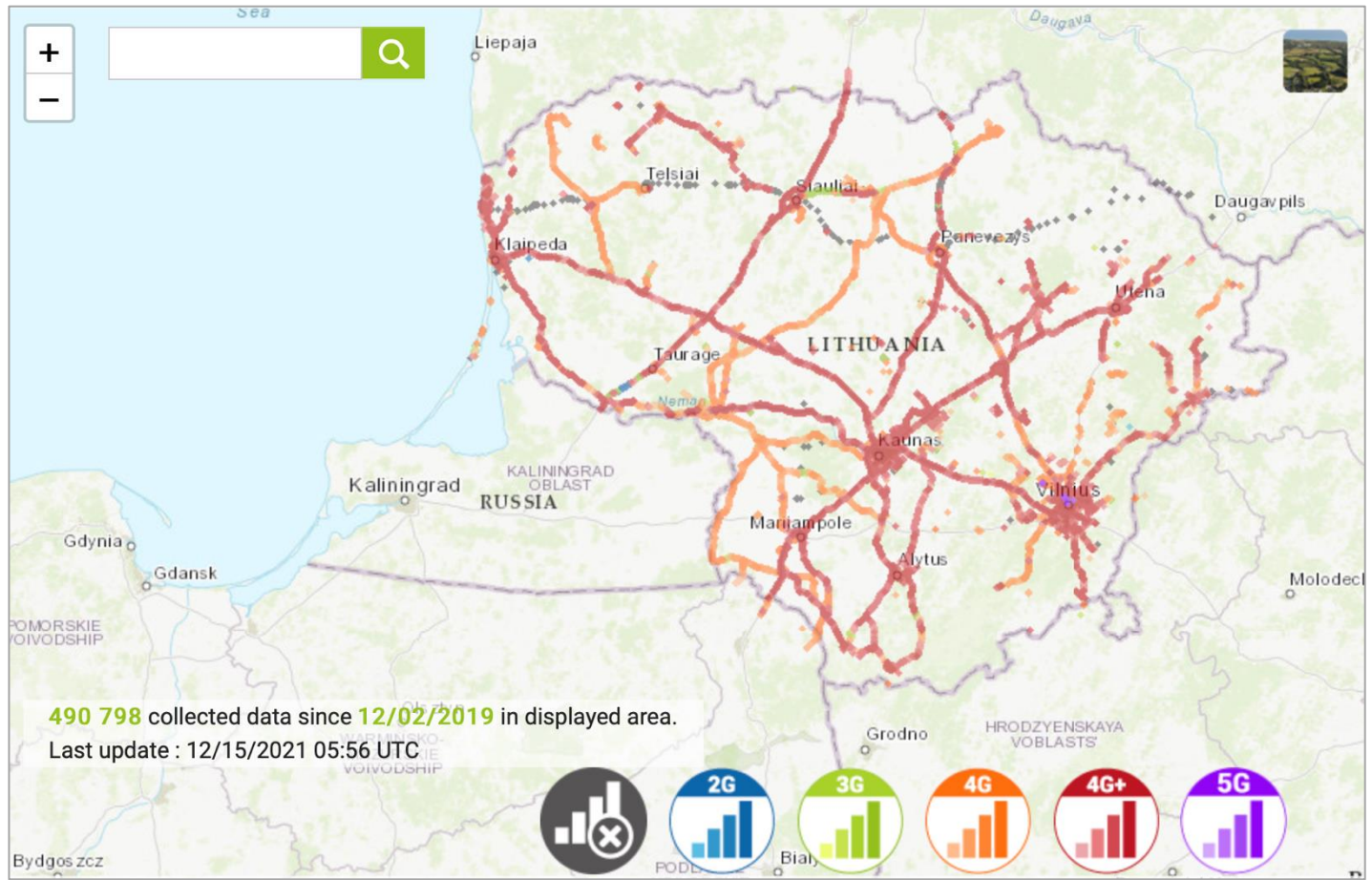

An example Try Before You Buy experience from T-Mobile USA

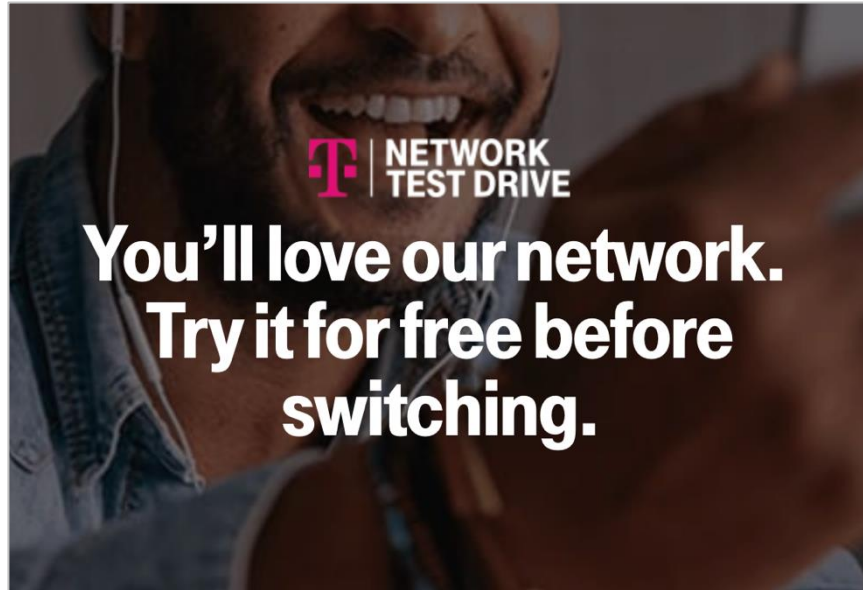

Try T-Mobile free for 30 days or 30GB of data and experience our expanded network without leaving your current carrier or losing your phone number.

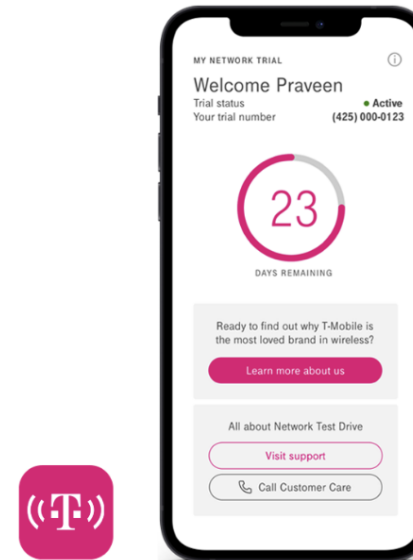

IPHONE XS OR NEWER

Get the Test Drive app today.

If you have the iPhone XS or newer, download the Test Drive app to start your free trial and get 30GB of data and unlimited talk and text.





Partner Brand Promotions







Becoming a Global Brand



A Global Proposition

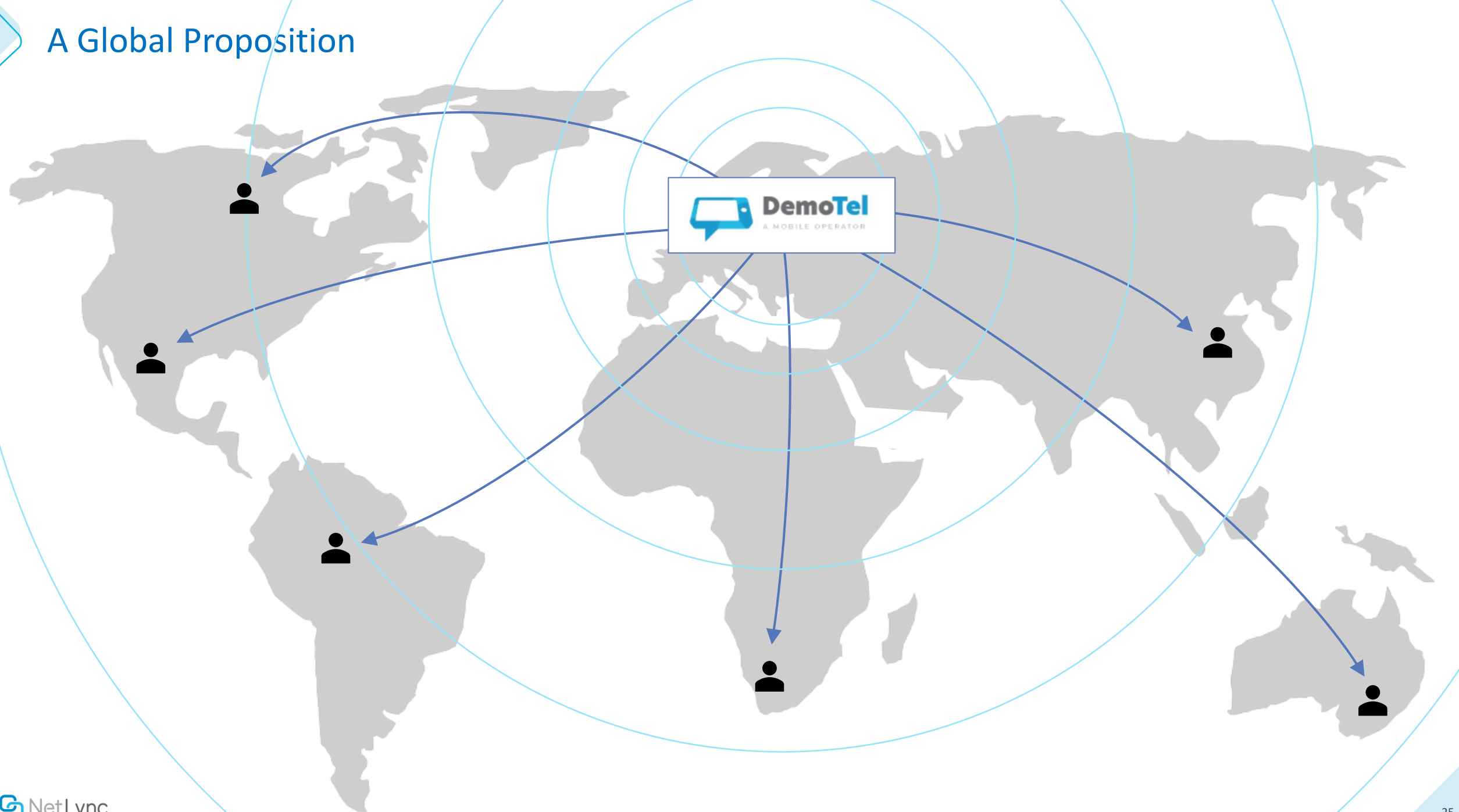

For more detailed information on the topics covered in this presentation, please have a read of our recent white paper:

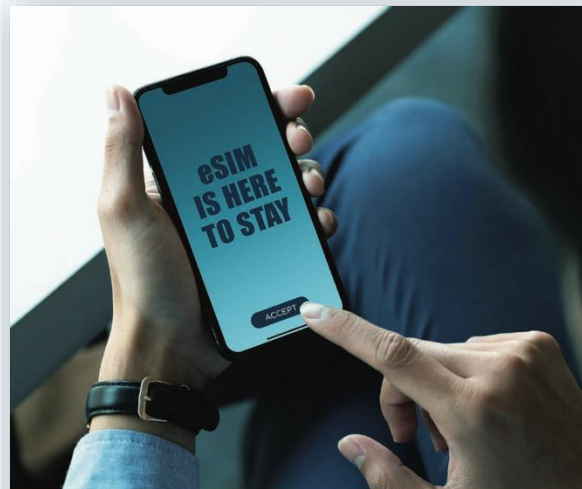

WHITEPAPER
eSIM: The technology mobile operators can't afford to ignore any longer

Published by **MOBILE VOICES LIVE** Sponsored by  NetLync



Thank you for
your attention

Gary.Waite@NetLync.com

